

Industrial & Laboratory Inert Oven

DN411I/611I



DN411I/611I

Model	
411I	611I
Operating Temperature Range	
Room temp. +15deg.C to 360deg.C	
Temp. Distribution Accuracy	
±.3.0deg.C (at 360deg.C)	
Internal Capacity (L)	
95	223

- Suitable for Curing Process in No Oxidation Environment.
- Suitable for Heat Insulation Test and Curing Process up to 360deg.C.
- Simple Operation by Interactive Key Input.
- Operation Monitor visualizes Controller Status, Temp and Temp. Changing.
- Incorporates with maximum 99 steps, 99 patterns program controller with repeat function.
- Loaded with Total Operation Hours Timer.
- N2 Gas Flow Amount Controllable.

■ Specifications

Model	DN411I	DN611I
Performance		
Convection Type	Forced Convection	
Operating Temp. Range	Room Temp. +15 to 360deg.C	
Temp. Adjustment Accuracy	±0.2deg.C (at 360deg.C)	
Temp. fluctuation	±0.6deg.C (at 360deg.C)	
Temp. Distribution Accuracy	±3.0deg.C (at 360deg.C)	
Temp. Gradient	12deg.C (at 360deg.C)	20deg.C (at 360deg.C)
Time to Reach to Max. Temp.	Approx. 60min.	
Nitrogen Substitution Time Required	Approx. 30 mins (ordinary temp with nitrogen concentration is 2%)	Approx. 70 mins (ordinary temp with nitrogen concentration is 2%)
Components		
Interior / Heat Insulation Material	Stainless Steel / Glass Wool + Ceramic Fibre	
Heater	SUS Pipe Heater 3.0kW	SUS Pipe Heater 4.0kW
Fan	Sirocco Fan, Condenser Type Motor 30W	
Flow Meter, Gas Carrier	Max. Flow 30L/min, O.D. 9mm Hose Nipple	
Temp. Control Type	PID Control by Micro Computer	
Temp. Setting Type	Digital Setting by UP/DOWN Key	
Temp. Display	Digital Indication by Green LED	
Other Display	Temp. Pattern Display for Operating Display by LED	
Timer / Timer Resolution	1min. to 99hrs. 59min. or 100hrs. to 999hrs. / 1min. or 1hrs.	
Operating Function	Fixed Temp. Operation, Automatic Start, Automatic Stop, Quick automatic stop, Program Operation	
Additional Function	Calendar time(24 hours), Calibration Off Set Function, electricity consumption, CO2 discharge, Heater output operation display monitor, power failure return mode, user configuration information saving/summoning.	
Heater Circuit Control / Sensor	Triac Zero-cross Type / K-Thermocouple (Double Sensor)	
Safety Device		
Safety Countermeasure	Self Diagnosis Function (Sensor, Heater, Fan, Triac, Main Relay, Automatic Overheat Prevention), Key Lock Function, Independent Overheating Prevention, Door Switch, Electric Leakage Breaker	
Standard		
Internal Dimensions	W470 x D450 x H450mm	W620 x D600 x H600mm
External Dimensions	W640 x D695 x H915mm	W790 x D845 x H1,065mm
Internal Capacity	95L	223L
Shelf Max. Load	Approx. 30kg / shelf	
Shelf Support Qty. / Pitch	12pcs. / 30mm	17pcs. / 30mm
Power	1-phase, AC200V, 50/60 Hz, 16A	1-phase, AC200V, 50/60 Hz, 21A
Weight	Approx. 90kg	Approx. 130kg

■ Control Panel



■ Stand (Optional Item)



■ Overheat prevention



■ N2 gas entrance port



■ Temp rise curve

DN4111

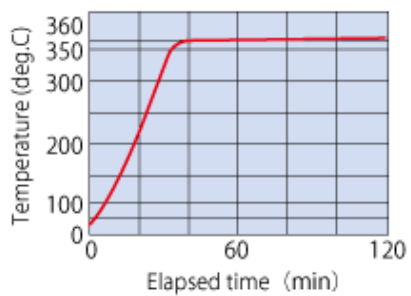

DN6111

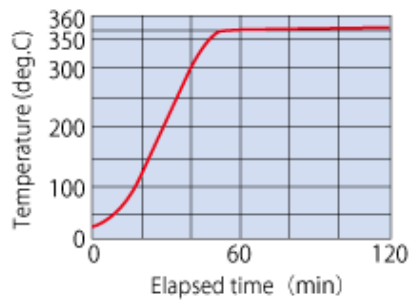

■ N2 gas substitution performance curve

DN411I

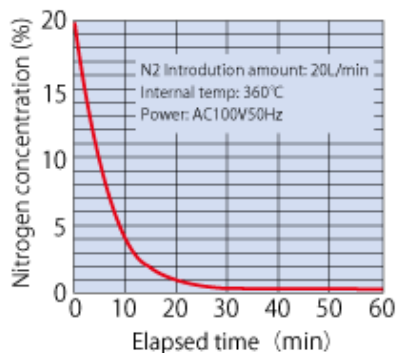

DN611I

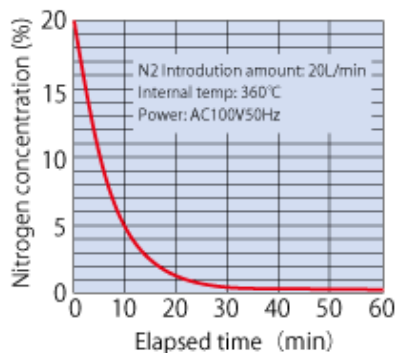

■ 9 points of distribution reference data

Model	Top right back	Top left back	Top right front	Top left front	Bottom right back	Bottom left back	Bottom right front	Bottom left front	Center
DN411I	359	358	363	361	359	359	359	356	359
DN611I	361	357	362	357	359	355	350	350	357

(Deg.C)

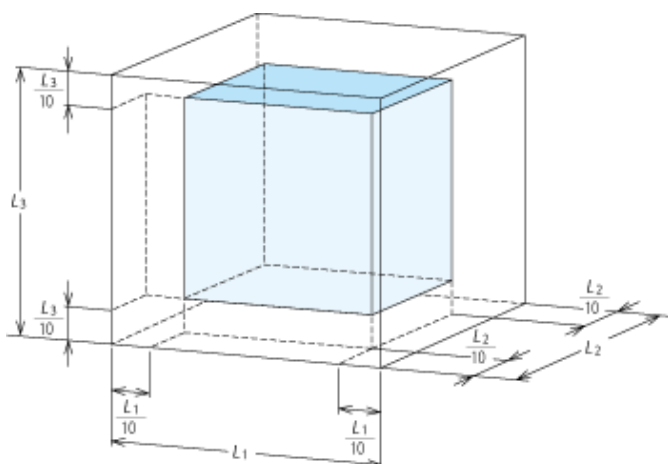

■ Optional Item

Remark	Description	Product Code
	Stand OH41(for DN410H/I)	212477
	Stand OH61(for DN610H/I)	212478
	Stainless wire shelf (with support 2 pcs., loading up to 30 kg/shelf) for DN411H/I	211063
	Stainless wire shelf (with support 2 pcs., loading up to 30 kg/shelf) for DN611H/I	211064
	Stainless punching metal shelf (loading up to 15kg/shelf) for DN411H/I	211098
	Stainless punching metal shelf (loading up to 15kg/shelf) for DN611H/I	211099
	External Communication Adapter set	211880
●	Additional cable port, 25mm dia	281056
●	Additional cable port, 50mm dia	281057
●	External Communication terminal	212975
●	Temperature output terminal	212976
●	External alarm output terminal	212977
●	Time up output terminal	212978
●	Operation signal output terminal	212979
●	Event output terminal	212980

Inner tank**Dimensions (mm)**

DN411I

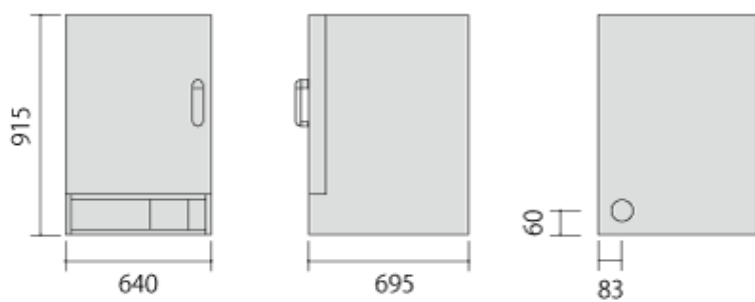

DN611I

